

Manual de instrucciones  
Instruction manual  
Manuel d'instruction  
Betriebsanleitung  
Manuale di funzionamento

**DIGITAL**

**IKM0993**

**CALYPSO**  
WATCHES

# IKM0993

---

---

■	MANUAL DE INSTRUCCIONES	3
■	INSTRUCTION MANUAL	27
■	MANUEL D'INSTRUCTION	51
■	BETRIEBSANLEITUNG	75
■	MANUALE DI FUNZIONAMENTO	99

## 1. MODO DE VISUALIZACIÓN Y OPERACIÓN DE LOS BOTONES

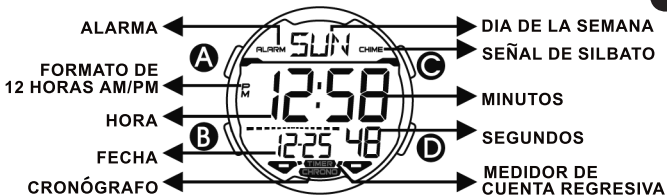

**A** AJUSTE / RECUPERAR

**C** AVANZAR / INICIO /  
VUELTA/PARCIAL

**B** MODO

**D** RETIRARSE / PARADA /  
AJUSTE / LUZ

## 2. COMO CAMBIAR EL MODO DE VISUALIZACIÓN

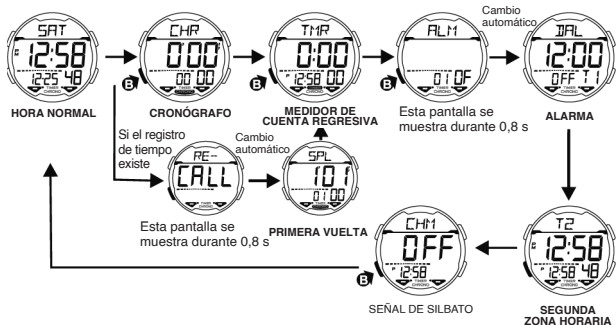

### 3. COMO VISUALIZAR EL MES Y LA FECHA



HORA NORMAL



PRESSIONE

MES Y FECHA

## 4. AJUSTE DE LA HORA NORMAL

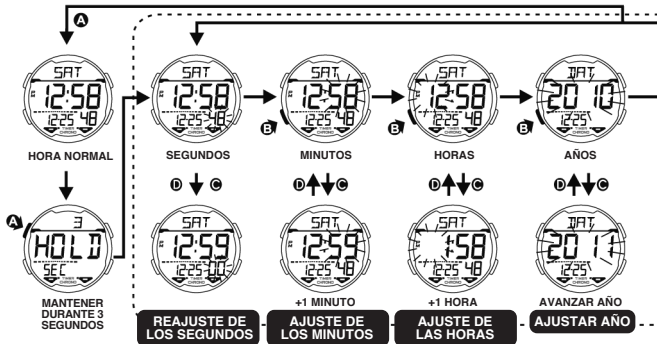

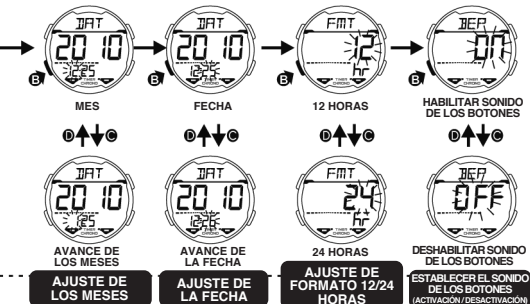

### REAJUSTE DE LOS SEGUNDOS

- Los minutos no avanzan y los segundos vuelven a cero al ajustar los segundos antes de 30 segundos.
- Los minutos avanzan y los segundos vuelven a cero al ajustar los segundos después de 30 segundos.

- Pulse "C" para avanzar el ajuste. Sostenga "C" durante más de 2 segundos para avanzar el ajuste rápidamente.
- Pulse "D" para invertir el ajuste.

Volver a la visualización de la hora normal. La semana se establecerá automáticamente.

## 5. COMO UTILIZAR EL CRONÓGRAFO

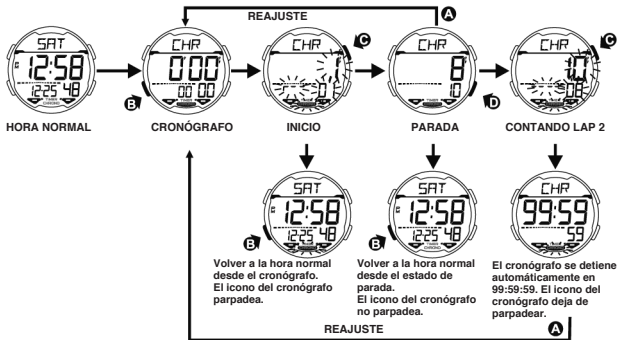



## 6. COMO CAMBIAR EL MODO VUELTA / PARCIAL

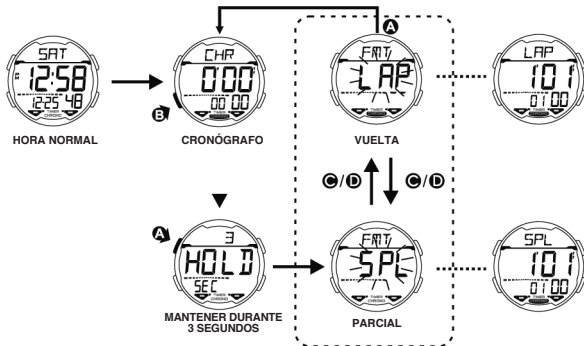

## 7. COMO AJUSTAR OPERACIÓN DE SPLIT Y LAP

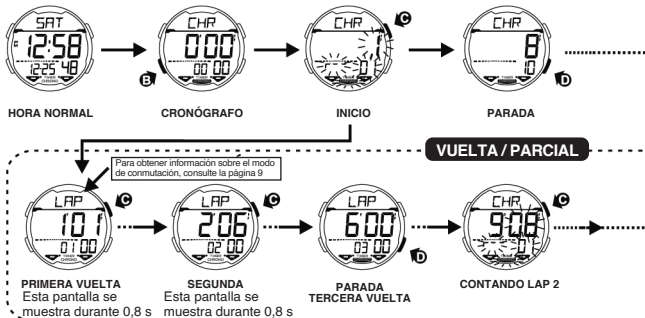

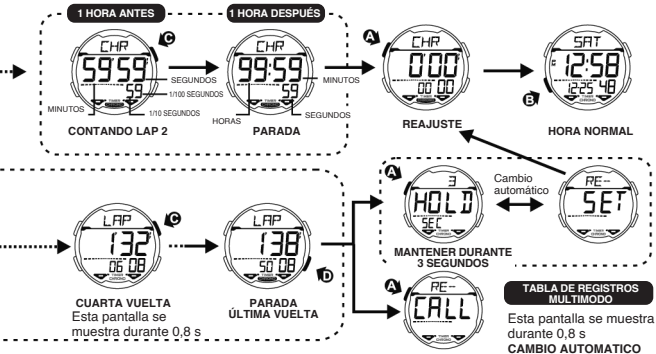

## 8. COMO UTILIZAR LA FUNCIÓN DE RECUPERACIÓN

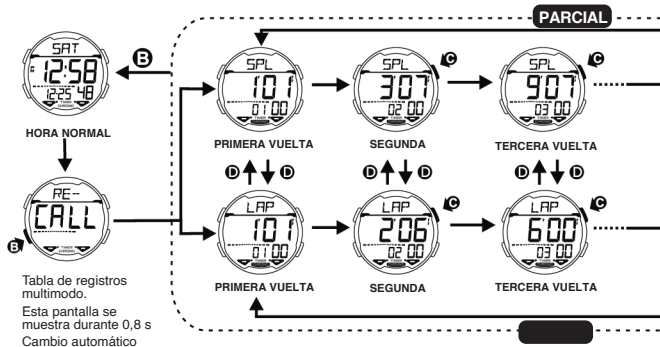

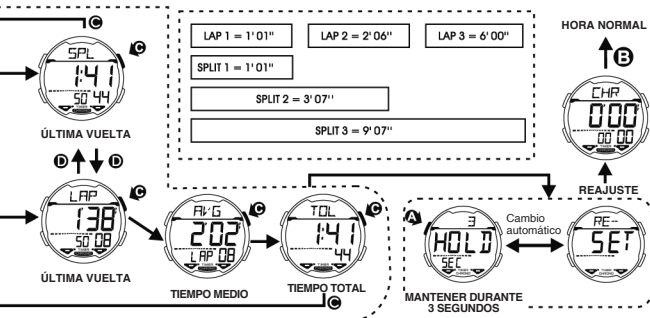

## 9. COMO UTILIZAR EL MEDIDOR DE CUENTA REGRESIVA

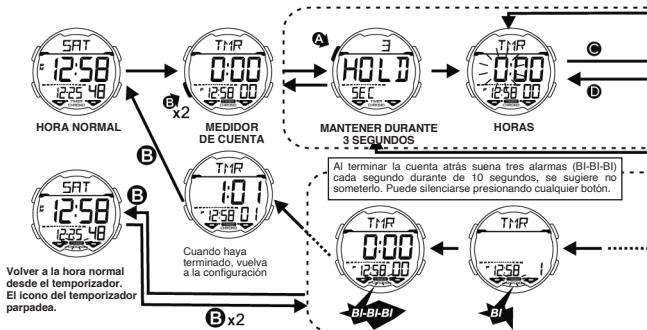

## AJUSTE DEL TEMPORIZADOR PARA LA CUENTA



En el intervalo de 10 segundos, suena una alarma (BI) cada segundo.

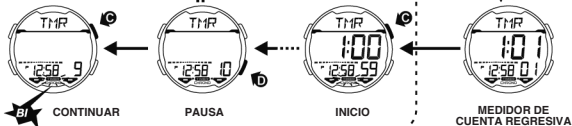

## 10. COMO ESTABLECER LA HORA DE LA ALARMA DIARIA

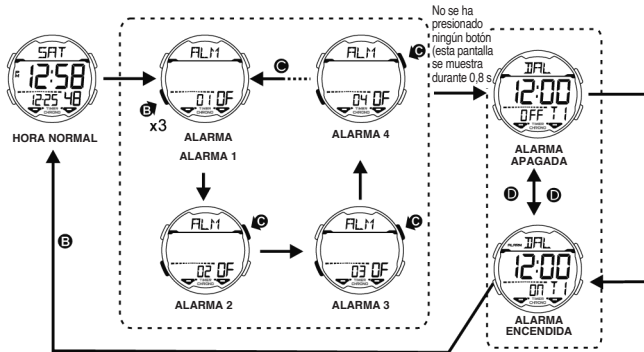



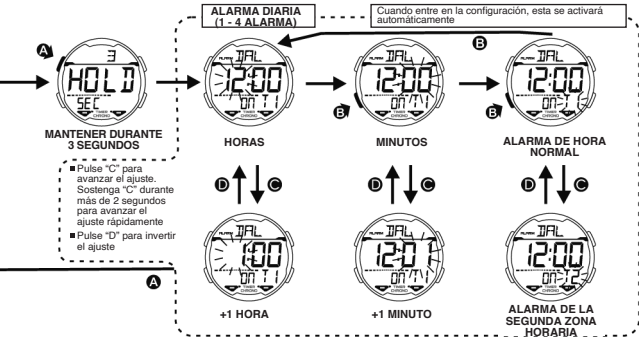

## 11. COMO ESTABLECER LA HORA DE LA ALARMA DIARIA

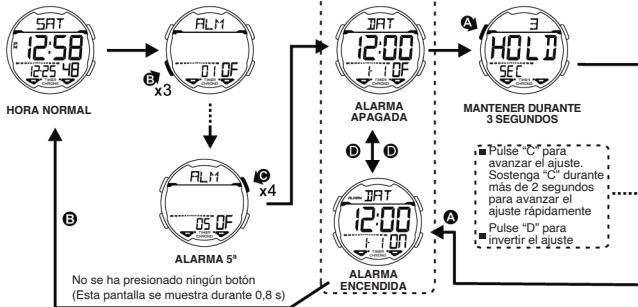

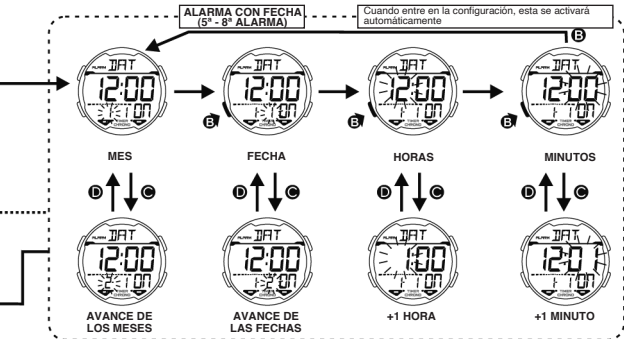

## 12. AJUSTE DE LA SEGUNDA ZONA HORARIA

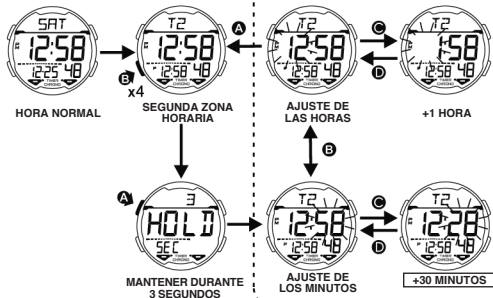

- Pulse "C" para avanzar el ajuste. Sostenga "C" durante más de 2 segundos para avanzar el ajuste rápidamente
- Pulse "D" para invertir el ajuste

## 13. COMO ACTIVAR Y DESACTIVAR EL SONIDO DE CADA HORA



HORA NORMAL

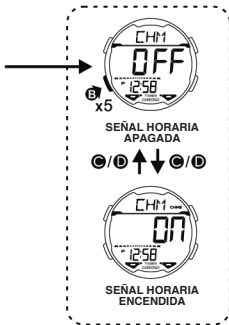

## 14. USO DE LA LUZ

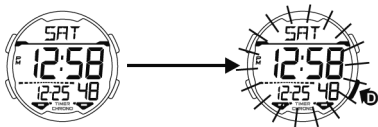

1. La iluminación del reloj utiliza una luz electroluminiscente (EL) que tiende a perder potencia después de usos muy prolongados.
2. Bajo la luz solar directa es difícil ver la iluminación que proporciona la luz de la pantalla.

1. Sonido de los botones: ACTIVAR o DESACTIVAR. Consulte la sección “Cómo establecer la visualización de funciones”.
2. Pitidos cada vez que se presiona un botón, excepto el botón LIGHT.
3. El botón solamente pitará una vez cuando se presione y se mantenga pulsado.
4. Duración de la alarma: 20s, dos pitidos breves por segundo. Un pitido cada hora.
5. El sonido de TIMER tiene prioridad sobre el sonido de ALARM.

## 16. CUIDADO DE SU RELOJ

1. Este reloj contiene componentes electrónicos. No intente abrir la caja o remover la tapa posterior.
2. No oprimir los botones de su reloj bajo la superficie del agua, nadando o practicando submarinismo.
3. Si por cualquier motivo llegase a aparecer agua o condensación en el reloj hágalo chequear inmediatamente. El agua puede corroer los componentes electrónicos dentro de la caja.
4. Evite impactos severos. El reloj está diseñado para resistir impactos bajo condiciones normales de uso. Se sugiere no someterlo a impactos severos, al uso inadecuado o caídas bruscas sobre superficies duras.
5. Evite exponer el reloj a temperaturas extremas.
6. Limpie su reloj únicamente con agua y un paño suave. Evite el uso de productos químicos especialmente de jabón.
7. Mantenga su reloj lejos de cualquier campo eléctrico o estático.



## 17. CARACTERÍSTICAS Y ESPECIFICACIONES

1. Modo de tiempo: hora, minutos, segundos, mes, fecha y día de la semana.
2. Función:
  - Función de temporizador (100 horas), 50 vueltas/parciales, vuelta media.
  - Medidor de cuenta regresiva / Señal de silbato.
  - 8 alarmas (4 alarmas diarias y 4 alarmas de fecha)
  - Formato de 12/24 horas.
  - Segunda zona horaria.
  - Función de ACTIVACIÓN / DESACTIVACIÓN del sonido de los botones
  - Mañana / Tarde, Luz Electroluminiscente.
3. Precisión a temperaturas normales (25°C):+ - 30 segundos por mes.
4. Rango de temperatura de operación normal: 10°C - 40°C



En aplicación de la normativa sobre los desechos de equipos eléctricos y electrónicos, los productos de relojería de cuarzo que se encuentran al final de su vida útil deben ser sometidos a una recogida selectiva en vistas a su posterior tratamiento. También puede depositar nuestros productos de relojería de cuarzo en uno de nuestros puntos de venta autorizados, así como en cualquier punto de recogida habilitado. La recogida selectiva, el tratamiento, la valoración y el reciclaje contribuyen a la salvaguarda de nuestro medio ambiente y a la protección de nuestra salud.

## 1. REGULAR DISPLAY AND BUTTON OPERATION



### BUTTON OPERATION

- |                     |                                   |
|---------------------|-----------------------------------|
| <b>A</b> SET/RECALL | <b>C</b> ADVANCE/START/SPLIT/LAP  |
| <b>B</b> MODE       | <b>D</b> RECEDE/STOP/ADJUST/LIGHT |

## 2. HOW TO CHANGE THE DISPLAY MODE

English

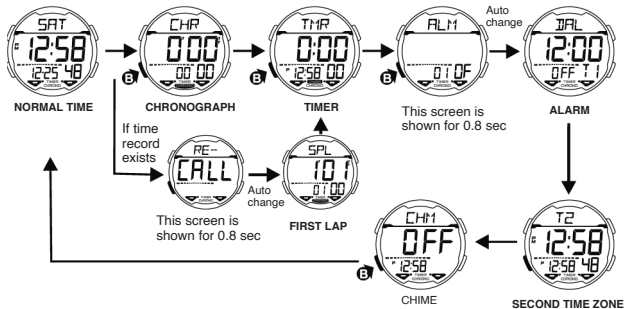

### 3. HOW TO DISPLAY CALENDAR

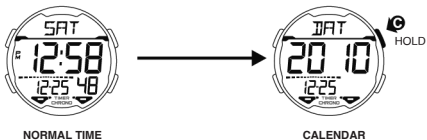

#### 4. HOW TO SET NORMAL TIME

English

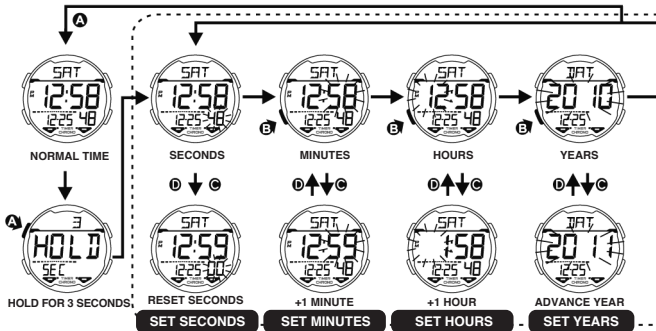

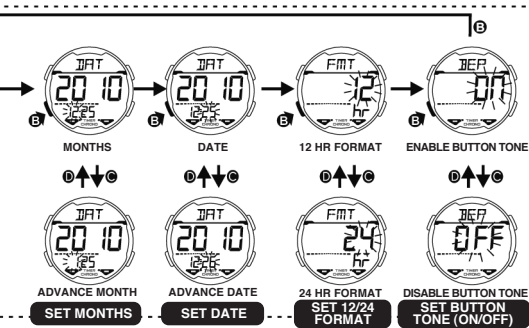
**SET SECONDS**

- Minutes do not advance and seconds return to zero when set seconds before 30 seconds.
- Minutes advance and seconds return to zero when set seconds after 30 seconds.

- Press "C" to advance the setting. Hold "C" for longer time than 2 seconds can advance the setting rapidly.
- Press "D" to reserve the setting.

Return to normal time display, the week will be set automatically

## 5. HOW TO USE THE CHRONOGRAPH

English

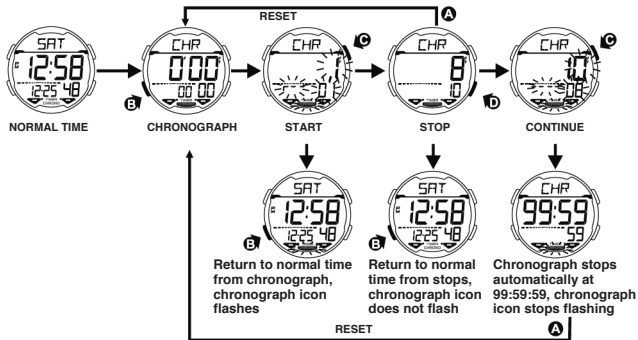



## 6. HOW TO CHANGE THE LAP/SPLIT MODE

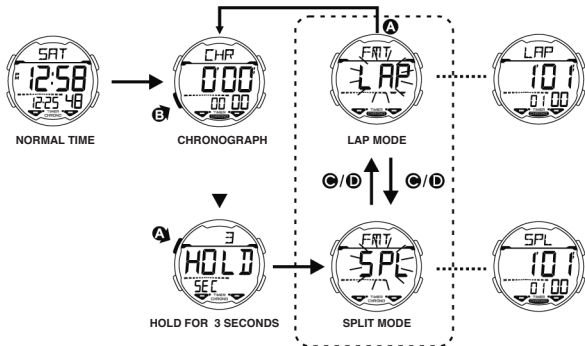

English

## 7. HOW TO SET THE SPLIT OR LAP OPERATION

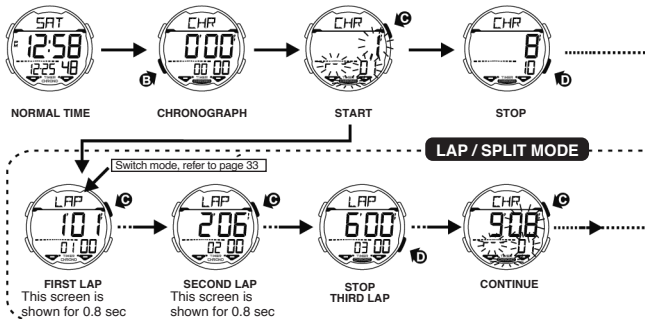

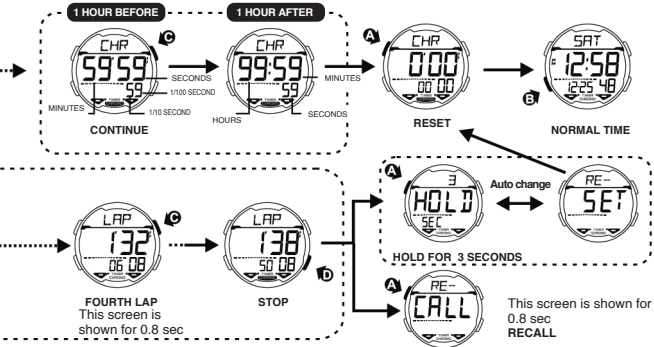

## 8. HOW TO USE THE RECALL

English

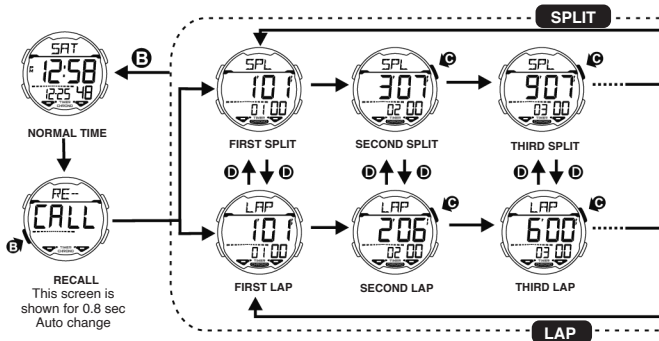

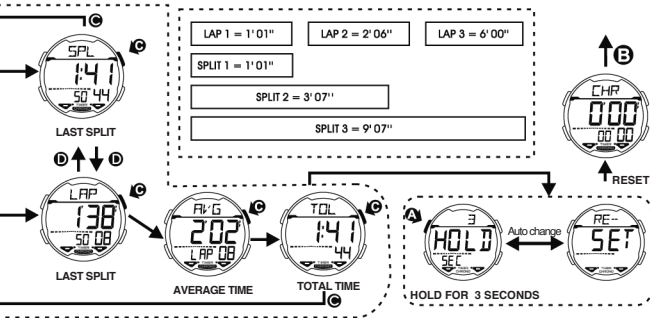

## 9. HOW TO USE TIMER

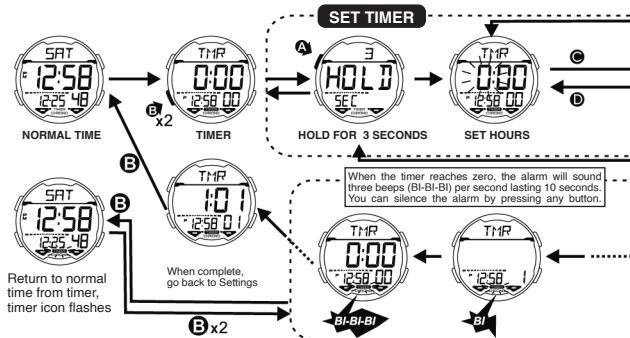

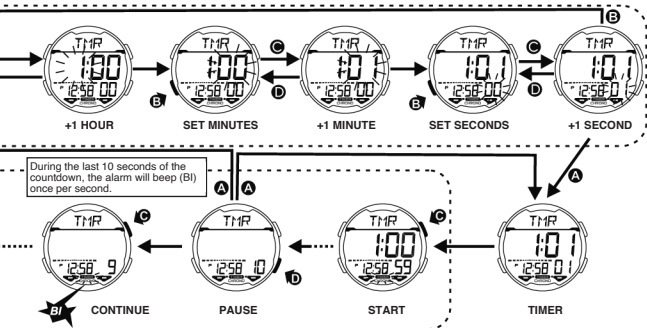

## 10. HOW TO SET DAILY ALARM TIME

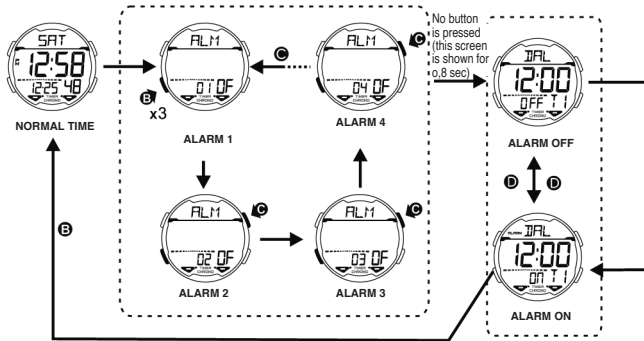



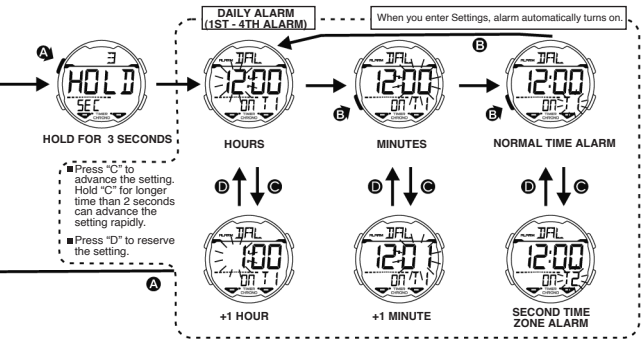

## 11. HOW TO SET DATE ALARM TIME

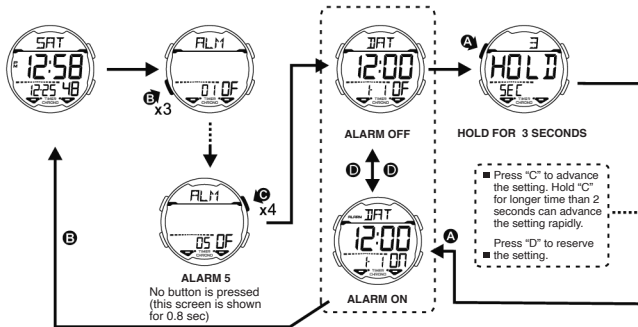

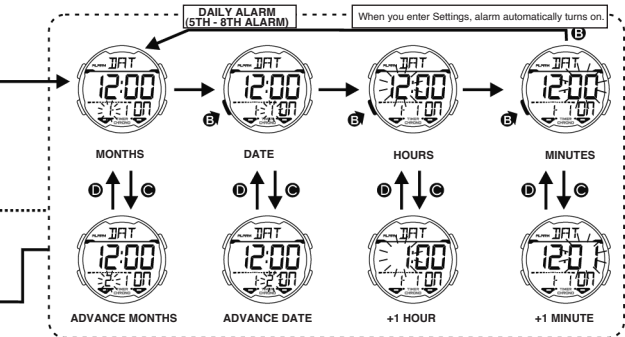

## 12. HOW TO SET SECOND TIME ZONE

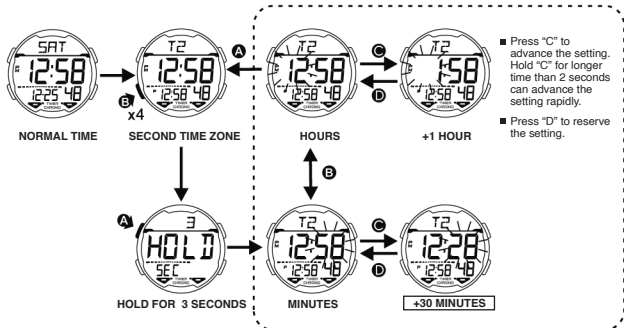

## 13. HOW TO SETUP HOURLY CHIME ON/OFF



NORMAL TIME



CHIME OFF



CHIME ON

## 14. HOW TO USE EL LIGHT

English

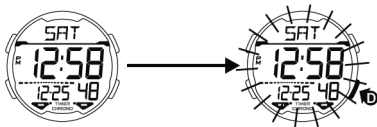

### NOTE

1. This watch features an electro-luminescent (EL) backlight, which tends to lose illuminating power after very long use.
2. The illumination provided by backlight may be hard to see under direct sunlight.

## 15. SOUND

1. Button tone: Turn ON or OFF, see “How to set function display.”
2. Beeps with each press of a button except for the LIGHT button.
3. The button will only beep once when pressed and held.
4. Alarmduration: 20 sec, two short beeps per second, beep once every hour.
5. The TIMER sound will take priority over the ALARM sound.

## 16. CARE OF YOUR WATCH

1. This watch contains electronic components. Never attempt to open the case or remove the back cover.
2. Do not operate push buttons below the surface of the water while swimming or diving.
3. Should water or condensation appear in the watch, have the watch checked immediately. Corrosion of electronic parts can occur inside the case.
4. Avoid severe impact. The watch is designed to withstand impact under normal use. It is inadvisable to subject it to severe impact of rough usage.
5. Avoid exposing the watch to extreme temperature.
6. Clean the watch with soft cloth and clean water only. Avoid using chemicals.
7. Keep your watch away from the conditions of strong electric field and static electricity.



## 17. FEATURES AND SPECIFICATIONS

1. Standard display mode: Hour, minutes, seconds, day of week, month, date.
2. Function:
  - 100-hour chronograph with memory for 50 laps/splits, and average lap.
  - 24-hour countdown timer.
  - 8 alarm (4 daily / 4 date) function with buzzer signal output.
  - Second time zone.
  - Hourly chime.
  - Perpetual calendar.
  - 12/24 hour format switch option
  - AM/PM & Electro-Luminiscent light.
  - Button tone ON/OFF Function.
3. Accuracy at normal temperature (25°C): 30 seconds a month.
4. Normal operating temperature range: 10°C - 40°C



---

By virtue of the regulations pursuant to the handling of waste products deriving from electronic and electrical equipment, end of lifecycle watch making products must be selectively collected for processing. You may therefore dispose of your quartz watch making products at any of our retail outlets or any other authorized collection point. The selective collection, processing, rating and recycling of these products helps contribute to safeguarding the environment and protecting our health.

## 1. AFFICHAGE NORMALE ET BOUTON D'UTILISATION

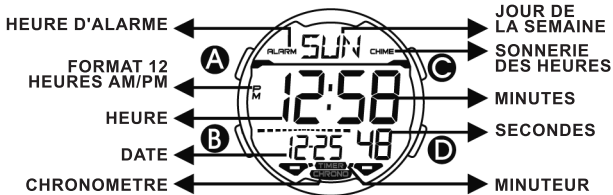

### BOUTONS D'UTILISATION

- |                             |   |
|-----------------------------|---|
| <b>A</b> RÉGLAGE / RAPPELER | <b>C</b> AVANCER / MARCHÉ / CHEVAUCHEMENT/PARTAGE |
| <b>B</b> MODE               | <b>D</b> RETOUR / ARRETÊR / ADJUSTMENT / LUMIÈRE  |

## 2. COMMENT CHANGER LE MODE D'AFFICHAGE

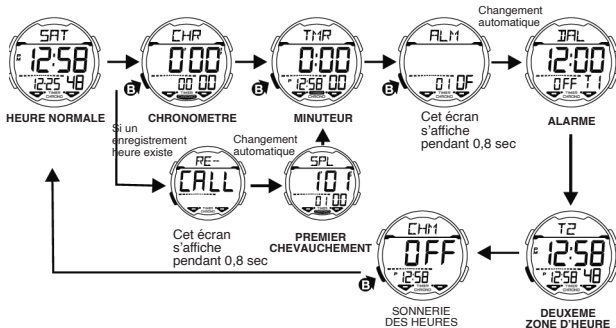

### 3. COMMENT AFFICHER LE MOIS, LA DATE



HEURE NORMALE



DATE



APPUYEZ

#### 4. COMMENT RÉGLER L'HEURE NORMALE

Français

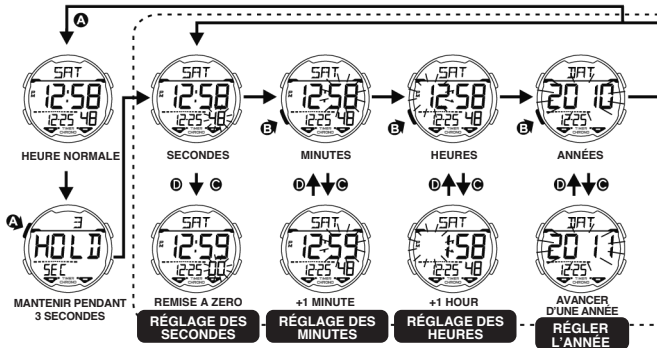

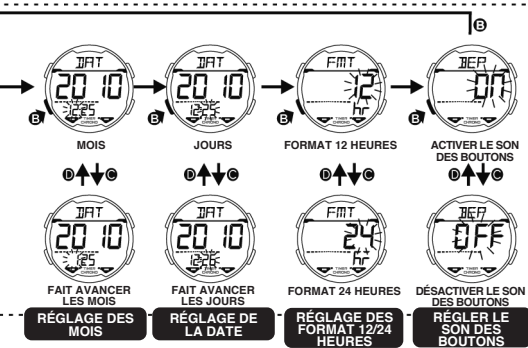

### RÉGLAGE DES SECONDES

- Les minutes n'augmentent pas et les secondes reviennent à zéro lorsqu'elles sont définies 30 secondes avant.
- Les minutes augmentent et les secondes reviennent à zéro lorsqu'elles sont définies 30 secondes après.

- Appuyez sur "C" pour augmenter la valeur. Maintenez "C" appuyé pour plus de 2 secondes afin d'augmenter rapidement la valeur.
- Appuyez sur "D" pour diminuer la valeur.

Retourner à l'affichage de l'heure normale, la semaine sera paramétrée automatiquement

## 5. COMMENT UTILISER LE CHRONOMÈTRE

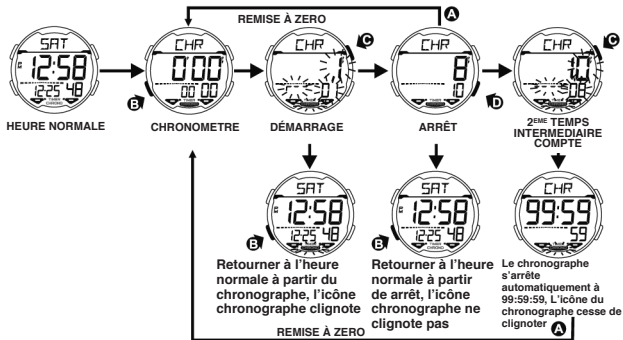



## 6. COMMENT CHANGER LE MODE CHEVAUCHEMENT / PARTAGE

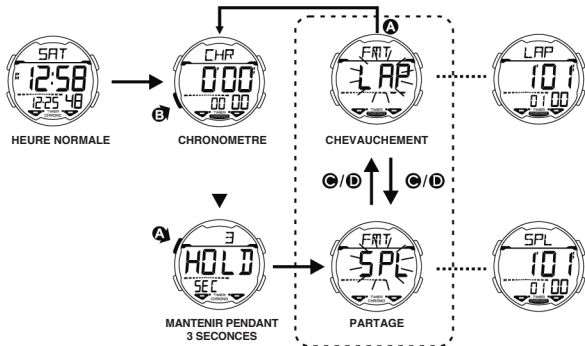

## 7. COMMENT RÉGLER L'UTILISATION DES COUPURES OU DES

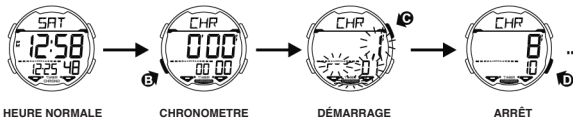

### CHEVAUCHEMENT / PAR-

Pour changer de mode, voir page 57

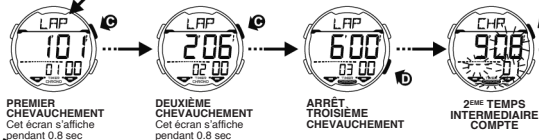

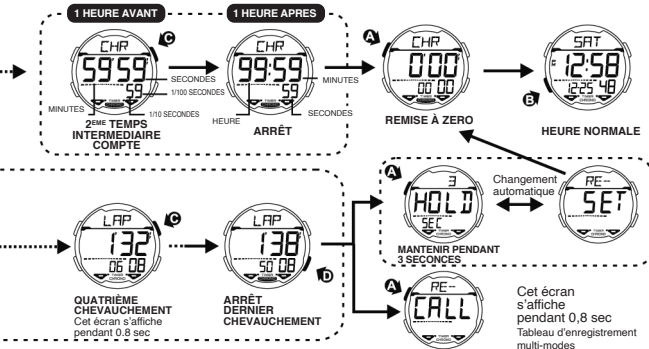

## 8. COMMENT UTILISER LA FONCTION RAPPELER

Français

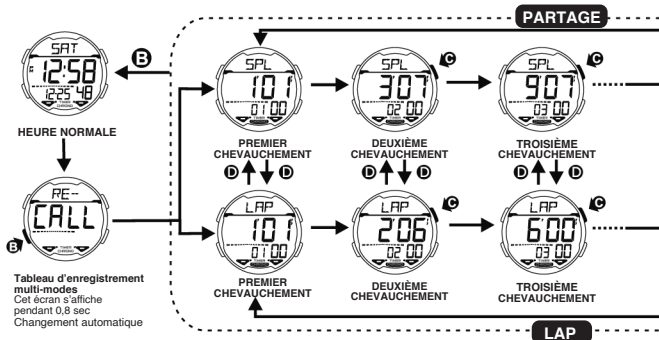

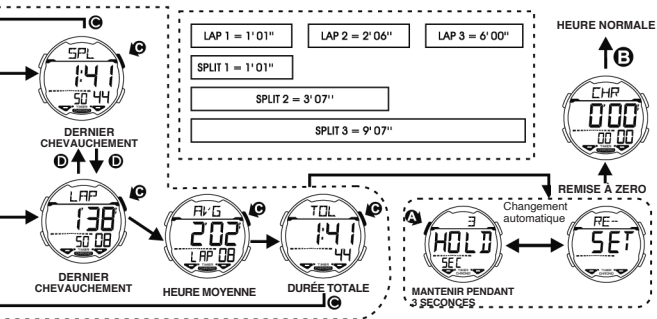

## 9. POUR UTILISER LE MINUTEUR DU COMPTE A REBOURS

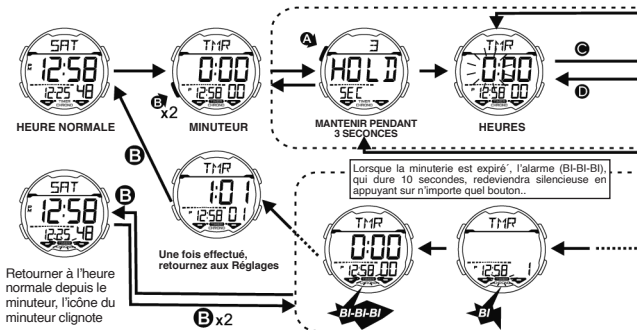

## POUR RÉGLER LE MINUTEUR DU COMPTE A RE-



+1 HEURE



MINUTES



+1 MINUTE



SECONDES



+1 SECONDE

Pendant les 10 dernières secondes du décompte, l'alarme ne produit qu'un bip (BIP) par seconde.



CONTINUER



PAUSE



DEMARRAGE



MINUTEUR

## 10. COMMENT RÉGLER L'HEURE DE L'ALARME QUOTIDIENNE

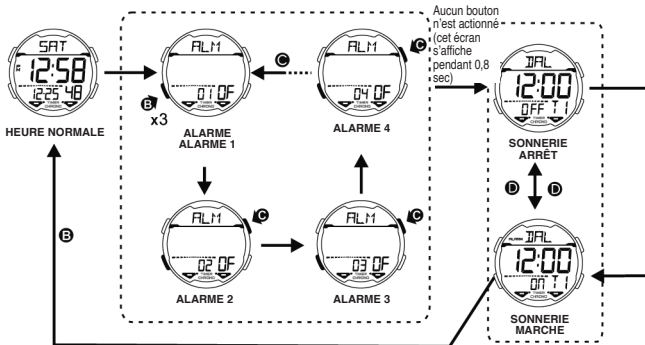



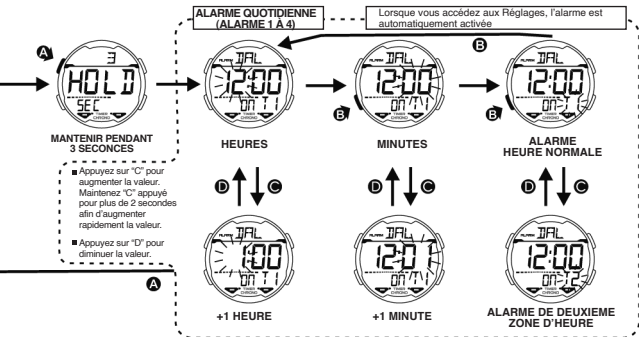

## 11. COMMENT RÉGLER L'HEURE DE L'ALARME DATE

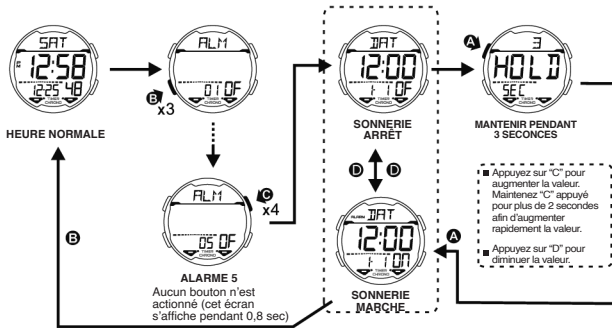

**ALARME QUOTIDIENNE  
(ALARME 5 A 8)**

Lorsque vous accédez aux Réglages, l'alarme est  
automatiquement activée



MOIS



**FAIT AVANCER  
LES MOIS**



JOURS



**FAIT AVANCER  
LES JOURS**



HEURES



**+1 HEURE**



MINUTES



**+1 MINUTE**

## 12. COMMENT RÉGLER L'HEURE D'UNE DEUXIEME ZONE

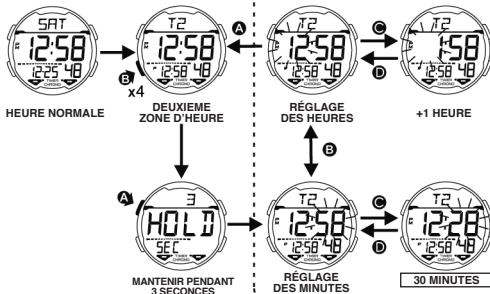

- Appuyez sur "C" pour augmenter la valeur. Maintenez "C" appuyé pour plus de 2 secondes afin d'augmenter rapidement la valeur.
- Appuyez sur "D" pour diminuer la valeur.

## 13. COMMENT ACTIVER / DESACTIVER LE CARILLON DES HEURES



HEURE NORMALE



ALARME ARRÊT



ALARME MARCHÉ

## 14. COMMENT ALUMER LA LUMIÈRE ÉLECTRO-LUMINESCENTE

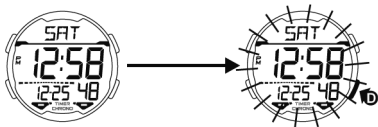

### NOTE

1. La lumière de fond de cette montre utilise une lumière électro-luminescente (EL), cette montre a tendance à perdre de sa puissance de luminosité après un très long usage.
2. La luminosité de la lumière de fond peut être difficile à distinguer sous les rayons directs du soleil.

1. Son des boutons: sur ON ou OFF, voir "Comment régler l'affichage des fonctions".
2. Bip à chaque pression d'un bouton, à l'exception du bouton LIGHT
3. Un seul bip va retentir si vous restez appuyé sur un bouton
4. Durée de l'alarme: 20 sec, deux bips courts par seconde. Un bip chaque heure
5. Le son du TIMER a priorité sur le son de ALARM

## 16. ENTRETIEN DE VOTRE MONTRE

1. Cette montre contient des composants électroniques de précision. Ne jamais tenter d'ouvrir le boîtier ou d'enlever le couvercle arrière.
2. Ne pas pousser les boutons sur l'eau ou lorsque vous nager ou faites de la plongée.
3. Si de l'eau ou de la condensation apparaît à l'intérieur de la montre, faites la vérifier immédiatement. L'eau peut corroder les parties électroniques à l'intérieur de boîtier.
4. Eviter les chocs violents. Cette montre est conçue pour résister à des chocs occasionnés par un usage normal, il n'est pas recommandé tomber sur une surface dure.
5. Eviter d'exposer cette montre à des températures extrêmes.
6. Nettoyer la montre avec un chiffon doux et de l'eau propre uniquement. Eviter d'utiliser des produits chimiques, en particulier le savon.
7. Tenir la montre éloignée des fortes conditions de champ électrique et d'électricité statique.



## 17. CARATÉRISTIQUES ET SPÉCIFICATIONS

1. Mode d'affichage standard: Heures, minutes, mois, date, jour de la semaine.
2. Fonctions:
  - Fonction de la minuterie (100 heures), 50 chevauchements/partages, chevauchement moyen.
  - Minuteur, Sonnerie des heures
  - 8 alarmes (4 alarmes quotidiennes, 4 alarmes avec date).
  - Sélecteur de format 12/24 heures.
  - Deuxieme zone d'heure.
  - Fonction ON/OFF du son des boutons.
  - Matin / Après-midi, lumière électroluminiscente.
3. Précision à une température normale (25°C) + - 30 seconds par mois.
4. Température limites pour un usage normale: 10°C - 40°C



En application de la réglementation sur les déchets des équipements électriques et électroniques, les produits horlogers à quartz en fin de vie font l'objet d'une collecte sélective en vue de leur traitement. Vous pouvez ainsi déposer nos produits horlogers à quartz dans l'un de nos points de vente agréés, ainsi que dans tout point de collecte habilité. La collecte sélective, le traitement, la valorisation et le recyclage contribuent à la sauvegarde de notre environnement et à la protection de notre santé.

## 1. GEWÖHNLICHE ANZEIGE UND KNOPFFUNKTIONEN

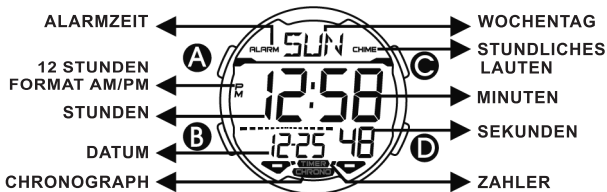

### KNOPFGEBRAUCH

- |                             |   |
|-----------------------------|---|
| <b>A</b> SET / WIEDERAUFRUF | <b>C</b> ERWEITERT / START / RUNDE / ZWISCHENZEIT |
| <b>B</b> MODUS              | <b>D</b> ZURÜCK / EINSTELLEN DER / STOP / LICHT   |

## 2. DAS WECHSELN DES ANZEIGENMODUS

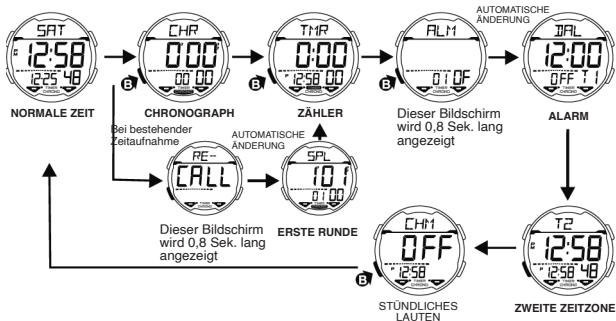

### 3. MONAT UND DATUM ANZEIGEN



NORMALE ZEIT



MONAT DATUM



## 4. DAS EINSTELLEN DER NORMALE ZEIT

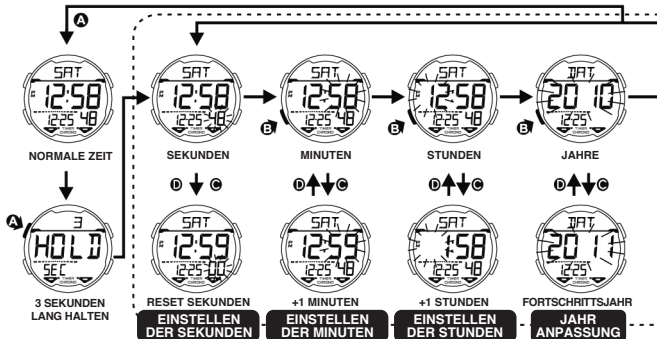

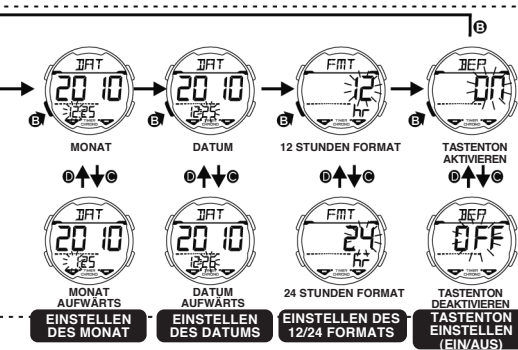

### EINSTELLEN DER SEKUNDEN

- Minuten laufen nicht weiter, und Sekunden gehen auf Null zurück, wenn Sekunden auf vor 30 Sekunden eingestellt werden.
- Minuten laufen weiter, und Sekunden gehen auf Null zurück, wenn Sekunden auf nach 30 Sekunden eingestellt werden.
- Drücken Sie auf "C", um die Einstellung vorzustellen. Halten Sie "C" für länger als 2 Sekunden gedrückt, um die Einstellung schnell vorzustellen.
- Drücken Sie auf "D", um die Einstellung zurückzusetzen.

Zurück zur normalen Zeitanzeige; die Woche wird automatisch eingestellt

## 5. DIE BENUTZUNG DES CHRONOGRAPH

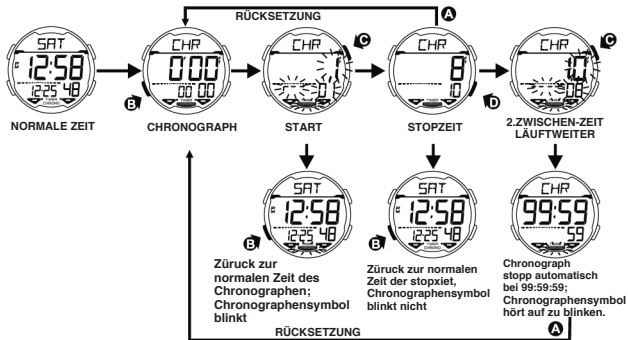



## 6. SO WECHSELN SIE DEN RUNDEN-/ZWISCHENZEITMODUS

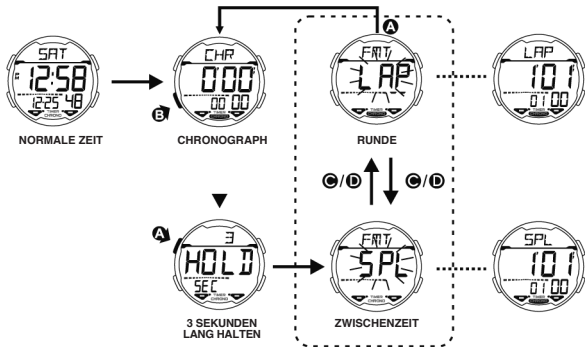

## 7. DAS EINSTELLEN DER SPLIT ODER LAP-FUNKTIONSGEBRAUCHS

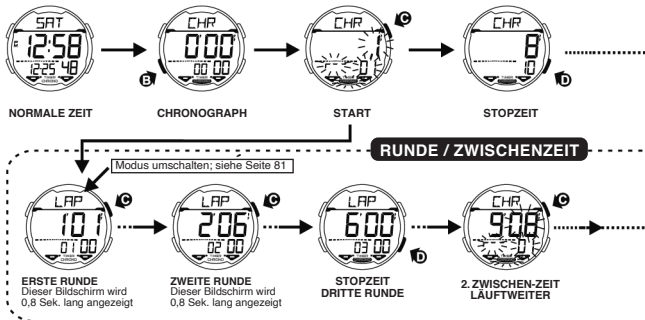

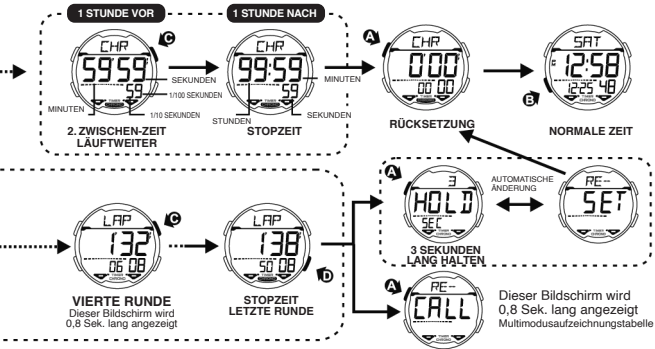

## 8. SA NUTZEN SIE DIE FUNKTION WIEDERAUF RUF

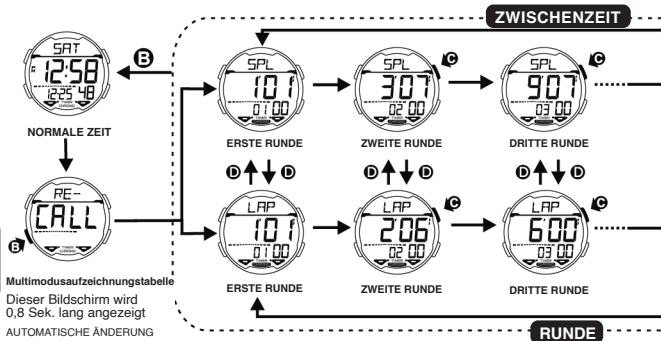

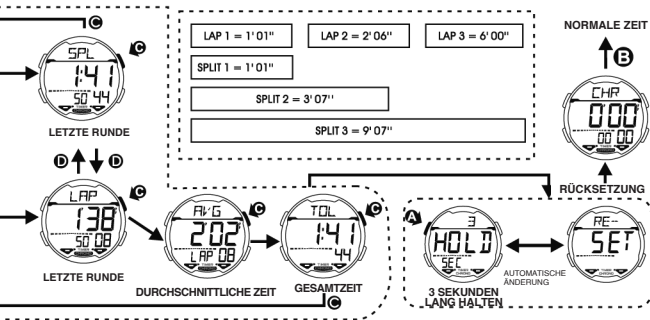

## 9. DAS EINSTELLEN DES COUNTDOWN ZÄHLERS

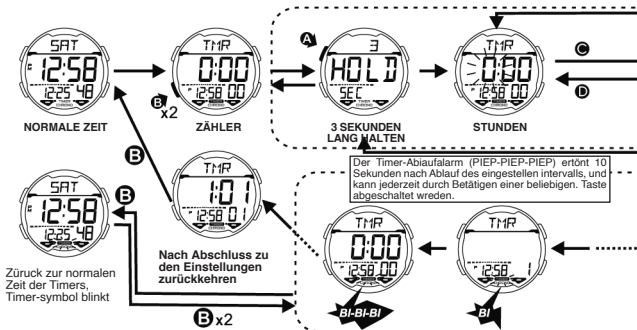

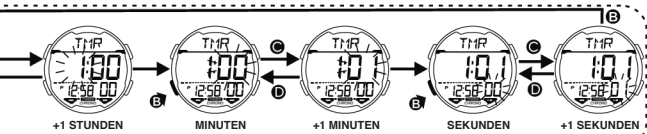

Vor der Einstellzeit von 10 Sekunden wird ein Alarm (BI) pro Sekunde zu vernehmen sein.

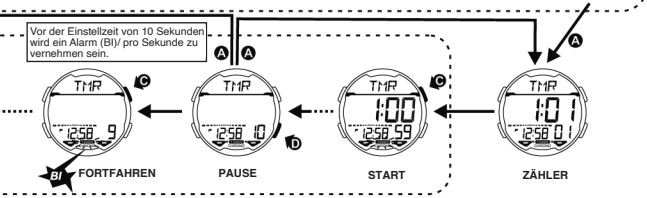

## 10. SO STELLEN SIE DIE TÄGLICHE ALARMZEIT EIN

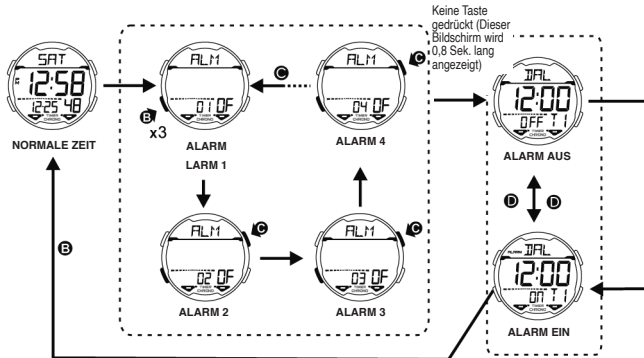



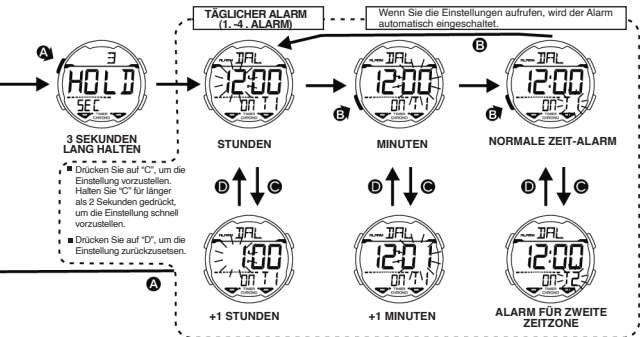

## 11. SO STELLEN SIE DIE TERMINALARMEIT EIN

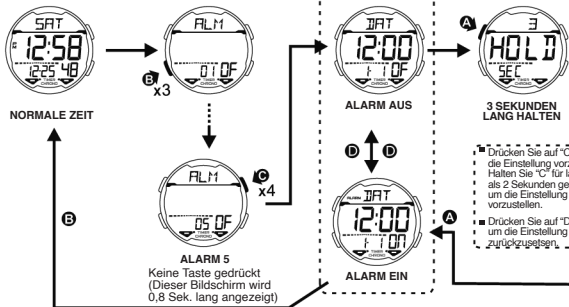

**TÄGLICHER ALARM  
(5. - 8. ALARM)**

Wenn Sie die Einstellungen aufrufen, wird der Alarm automatisch eingeschaltet.



MONAT



MONAT  
AUFWÄRTS



DATUM



DATUM  
AUFWÄRTS



STUNDEN



+1 STUNDEN



MINUTEN



+1 MINUTEN

## 12. ZEIT FÜR ZWEITE ZEITZONE PROGRAMMIEREN

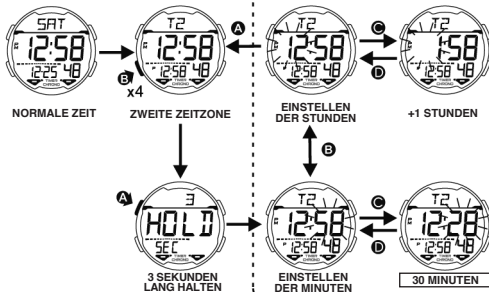

- Drücken Sie auf "C", um die Einstellung vorzustellen. Halten Sie "C" für länger als 2 Sekunden gedrückt, um die Einstellung schnell vorzustellen.
- Drücken Sie auf "D", um die Einstellung zurückzusetzen.

## 13. SO STELLEN SIE DEN STÜNDLICHEN GIGNALTON EIN / AUS



NORMALE ZEIT



STUNDENLÄUTEN AUS



STUNDENLÄUTEN EIN

## 14. DIE EL BELEUCHTUNG

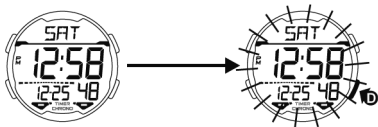

### BEACHTEN SIE

1. Die Beleuchtung der Uhr erfolgt durch ein elektrisch-lumineszierendes (EL) Licht. Die Uhr neigt nach sehr langer Benutzung dazu, die Beleuchtungskraft zu verlieren.
2. Die Beleuchtung der Uhr könnte schwer zu sehen sein, wenn unter sein, wenn unter direktem Sonnenlicht daraufgeschaut wird.

1. Tastenton: Ein-ausschalten; siehe "So stellen Sie die Funktionsanzeige ein".
2. Gibt beim Drücken einer Taste mit Ausnahme der Licht-Taste einen Ton aus.
3. Bei Gedrückhalten einer Taste gibt das Gerät nur einen Ton aus.
4. Alarmdauer: 20 Sek., zwei kurze Signaltöne pro sekunde. Ein Signalton pro Stunde.
5. Der Timer-Ton hat eine höhere Priorität als der Alarm-Ton.

## 16. BEHANDLUNG IHRER UHR

1. Diese Uhr verfügt über präzise elektronische Komponenten. Versuchen Sie niemals, das Gehäuse zu öffnen oder den Deckel der Rückseite zu entfernen.
2. Betätigen Sie die Knöpfe nicht unter Wasser während dem Schwimmen oder Tauchen.
3. Sollte Wasser oder Kondensierung in der Uhr auftauchen, lassen Sie sie bitte sofort überprüfen, Feuchtigkeit kann Korrosion der elektrischen Teile verursachen.
4. Verhindern Sie harte Stöße. Die Uhr ist geeignet, nur Stößen unter normalen Bedingungen standzuhalten. Es wird nicht empfohlen, sie übermäßig starken Stößen oder grober Behandlung auszusetzen oder sie auf harte Oberflächen fallen zu lassen.
5. Vermeiden Sie es, die Uhr extremen Temperaturen auszusetzen.
6. Reinigen Sie die Uhr nur mit einem sanften Tuch und sauberem Wasser. Vermeiden Sie Chemikalien, insbesondere Seife.
7. Halten Sie Ihre Uhr fern von Umgebungen mit starkem Elektrofeld und statischer Elektrizität.



## 17. FUNKTIONEN UND TECHNISCHE DATEN

1. Normalzeit-Anzeige-Modus: Stunden, Minuten, Sekunden, Monat, Wochentag, Datum.
2. Funktionen:
  - Timerfunktion (100 Stunden), 50 Runden / Zwischenzeiten, Durchschnittliche Runde
  - Zähler/Stündliches Lauten.
  - 8 Alarmer (4 tägliche Alarmer, 4 Datumsalarmer).
  - 12/24 Stunden Anzeigeformate wählbar.
  - Ein-/Ausschalten des Tastentons
  - Morgan / Nachmittag und Elektro-Lumineszenz-Anzeigebeleuchtung.
  - Zweite Zeitzone.
3. Genauigkeit unter normalen Temperaturen:  $\pm 30$  s/Monat.
4. Normalbräuchlicher Temperaturbereich: 10 -40 Grad Celsius.



Gemäß den Bestimmungen über die Behandlung von Abfällen durch Elektronik- und Elektro-Altgeräte sind Quarzuhrenprodukte, deren Lebensdauer abgelaufen ist, selektiv zu sammeln, um sie dem Recycling zuzuführen. Sie können Ihre Quarzuhrenprodukte daher in einer unserer Verkaufsstellen oder an einer beliebigen Sammelstelle abgeben. Die selektive Sammlung, die Verarbeitung, die Bewertung und das Recycling dieser Produkte ist ein Beitrag zum Umweltschutz und zum Schutz unserer Gesundheit.

## 1. MODALITÀ DI VISUALIZZAZIONE E FUNZIONI DEI TASTI

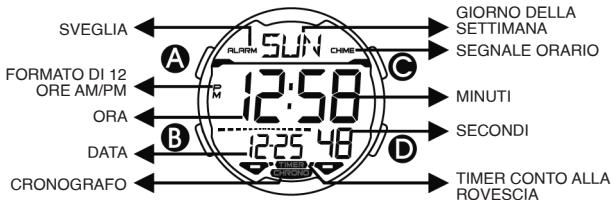

### FUNZIONI DEI PULSANTI

**A** IMPOSTAZIONE/RECUPERO

**B** MODALITÀ

**C** AVANZAMENTO/PARTENZA/GIRO/  
PARZIALE

**D** RITIRO/ARRESTO/IMPOSTAZIONE/  
LUCE

## 2. COME MODIFICARE LA MODALITÀ DI VISUALIZZAZIONE

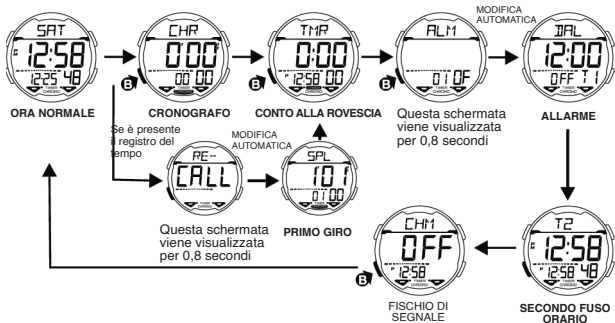

### 3. COME VISUALIZZARE IL MESE E LA DATA



ORA NORMALE



PREMERE

MESE E DATA

#### 4. REGOLAZIONE DELL'ORA NORMALE

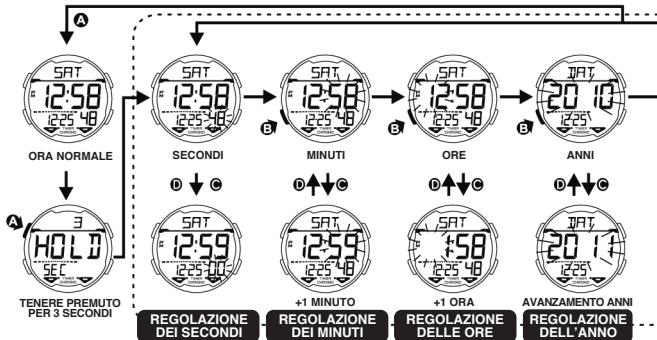

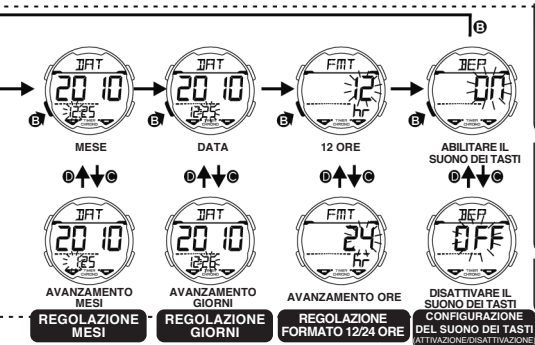

#### REGOLAZIONE DEI SECONDI

- I minuti non scorrono e i secondi vengono azzerati se la regolazione avviene prima dei 30 secondi.

- I minuti scorrono e i secondi vengono azzerati se la regolazione avviene dopo i 30 secondi.

- Premere "C" per proseguire con la regolazione. Tenere premuto il tasto "C" per più di 2 secondi per far avanzare rapidamente la regolazione.

- Premere "D" per invertire la regolazione.

Tornare alla visualizzazione normale dell'ora. La settimana verrà configurata automaticamente.

## 5. COME UTILIZZARE IL CRONOGAFO

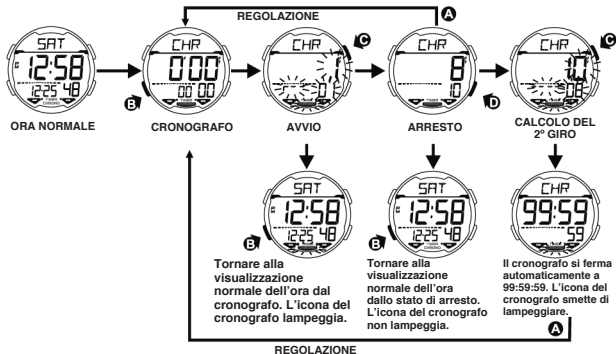



## 6. COME MODIFICARE LA MODALITÀ DI GIRO/PARZIALE

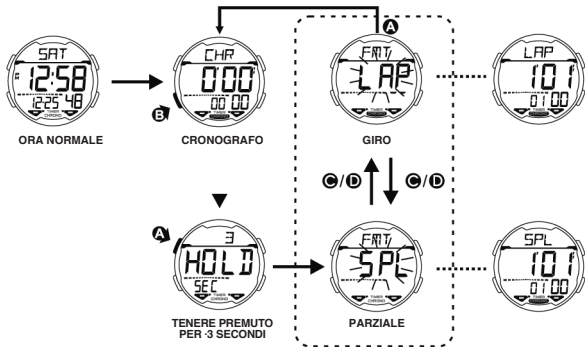

## 7. COME REGOLARE LA FUNZIONE DI GIRO e PARZIALE



ORA NORMALE



CRONOGRAFO



AVVIO



ARRESTO

### GIRO / PARZIALE

Per maggiori informazioni sulla funzione di commutazione, vedere alla pagina 105



**PRIMO GIRO**  
Questa schermata viene visualizzata per 0,8 secondi



**SECONDO GIRO**  
Questa schermata viene visualizzata per 0,8 secondi



**ARRESTO TERZO GIRO**



**CALCOLO DEL 2° GIRO**

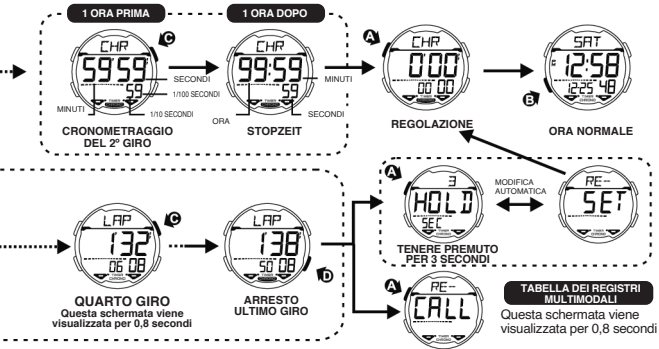

## 8. COME UTILIZZARE LA FUNZIONE DI RECUPERO PARZIALE

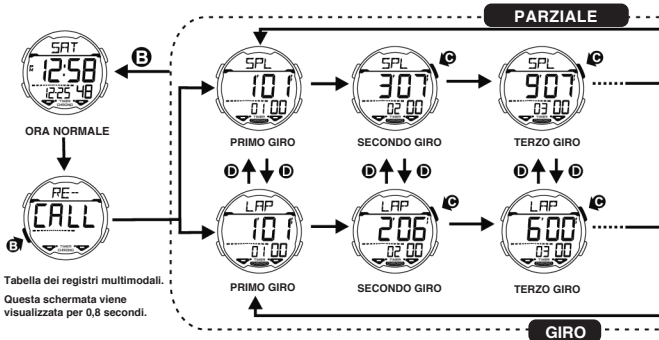

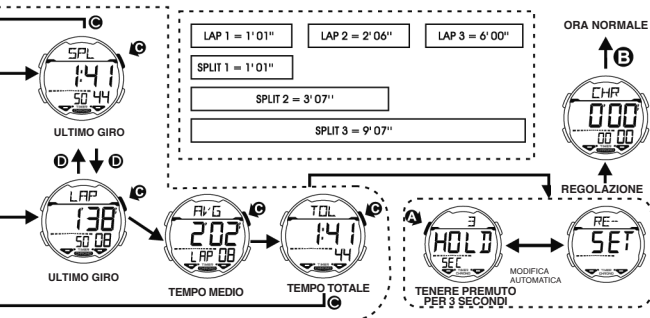

## 9. COME UTILIZZARE IL CONTO ALLA ROVESCIA

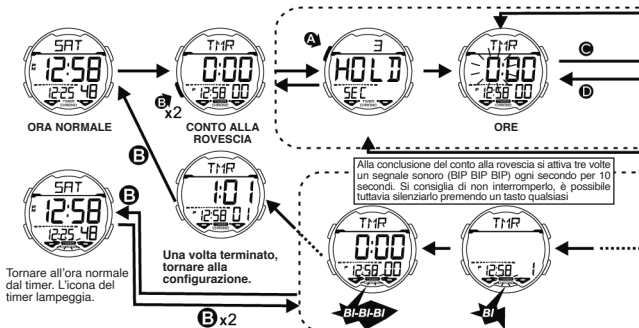

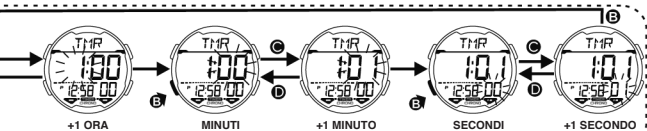

Per 10 secondi viene emesso un segnale di allarme ogni secondo.

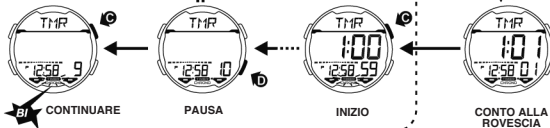

## 10. COME IMPOSTARE L'ORA DELL'ALLARME GIORNALIERO

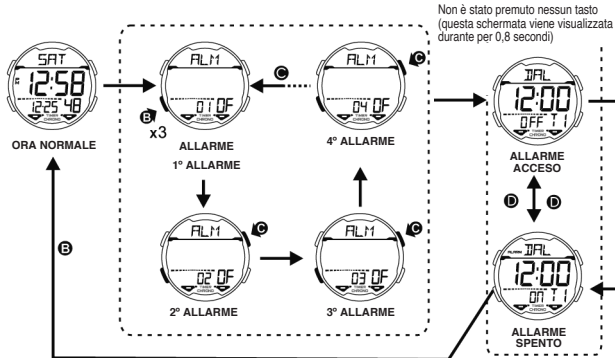



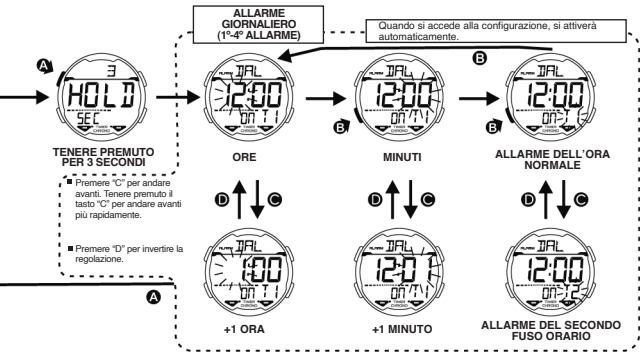

## 11. COME IMPOSTARE L'ORA DELL'ALLARME GIORNALIERO

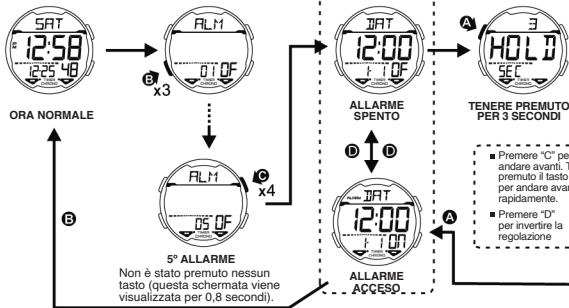

**ALLARME CON DATA  
(5°-8° ALLARME)**

Quando si accede alla configurazione, si attiverà automaticamente.



MESE



GIORNO



ORE



+ 1 ORA



MINUTI



+ 1 MINUTO

## 12. CONFIGURAZIONE DEL SECONDO FUSO ORARIO

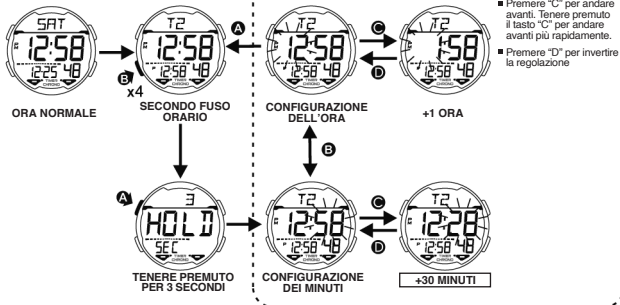

## 13. COME ATTIVARE E DISATTIVARE IL SEGNALE ORARIO



ORA NORMALE



SEGNALE ORARIO  
SPENTO



SEGNALE ORARIO  
ACCESO

## 14. UTILIZZO DELLA LUCE

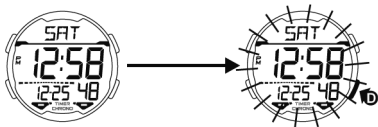

### Note:

1. L'orologio è dotato di retroilluminazione elettroluminescente (EL), che si può affievolire con l'uso in un periodo di tempo prolungato.
2. Se esposto direttamente alla luce del sole, la luce prodotta dalla retroilluminazione può non essere evidente.

1. Suono dei tasti: ATTIVARE o DISATTIVARE. Consultare la sezione “Come configurare la visualizzazione delle funzioni”.
2. Emissione di suoni a ogni selezione di un tasto, ad eccezione del tasto della LUCE.
3. Il tasto emetterà un suono una sola volta quando verrà tenuto premuto.
4. Durata dell'allarme: 20 secondi, due bip brevi ogni secondo. Un bip ogni ora.
5. Il segnale sonoro del TIMER ha priorità sull'ALLARME.

## 16. PRECAUZIONI PER IL VOSTRO OROLOGIO

1. Questo orologio contiene precise componenti elettroniche. Non provare, in nessuna circostanza, ad aprire la cassa o a rimuovere il coperchio posteriore.
2. Non utilizzare i pulsanti sotto della superficie dell'acqua, nuotando o in immersione.
3. In caso di acqua o condensa nel quadrante fare controllare l'orologio immediatamente. L'acqua può esercitare un'azione corrosiva sulle componenti elettroniche contenute nella cassa.
4. Non sottoporre l'orologio a forti impatti. L'orologio è stato studiato per un uso ordinario e resiste quindi a condizioni di normale impatto. Non sottoporre l'orologio a forti impatti, non farne un uso brusco e non lasciarlo cadere su superfici dure.
5. Non esporre l'orologio a temperature estreme.
6. Pulire l'orologio esclusivamente con un panno morbido e acqua pulita. Evitare l'uso di prodotti chimici, soprattutto sapone.
7. Mantenere l'orologio lontano da forti campi magnetici e da luoghi dove sia presente elettricità statica.



## 17. CARATTERISTICHE TECNICHE

1. Modalità temporale: ore, minuti, secondi, mesi, giorni e giorno della settimana.
2. 2. Funzione:
  - Funzione di timer (100 ore), 50 giri/parziali, mezzi giri
  - Timer di conto alla rovescia/Fischio di segnale
  - 8 allarmi (4 allarmi giornalieri e 4 allarmi in base alla data)
  - Formato orario 12/24 ore
  - Secondo fuso orario
  - Funzione di ATTIVAZIONE/DISATTIVAZIONE del suono dei tasti
  - Mattina/pomeriggio, luce elettroluminescente
3. Precisione a temperature normali (25°C): +/- 30 secondi al mese
4. Intervallo di temperatura per il funzionamento normale: 10 °C – 40 °C.



---

Ai sensi dei regolamenti relativi alla manipolazione dei rifiuti provenienti da assemblaggi elettrici ed elettronici, i prodotti d'orologeria ormai inutilizzabili devono essere raccolti separatamente per consentirne il trattamento. In qualsiasi nostro punto vendita o punto di raccolta autorizzato troverà gli appositi contenitori per lo smaltimento dei componenti del Suo orologio al quarzo. La raccolta differenziata, il trattamento, la valorizzazione ed il riciclaggio di tali prodotti contribuiscono alla salvaguardia dell'ambiente ed alla produzione della nostra salute.





**CALYPSO**  
**WATCHES**